

The LOGSTOR pre-insulated pipe system

Types of pipe systems currently available

- the Single Pipe system
- the TwinPipe system
- the DoublePipe system
- the FlexPipe system
- Curved pipes with diameters up to DN800 are available for all systems.

Joining systems

LOGSTOR joining systems are designed to deal effectively with all the challenges traditionally associated with joining pipe sections together.

These systems reduce the number of pre-insulated components and joints required, and ensure rapid, safe installation at the lowest possible cost.

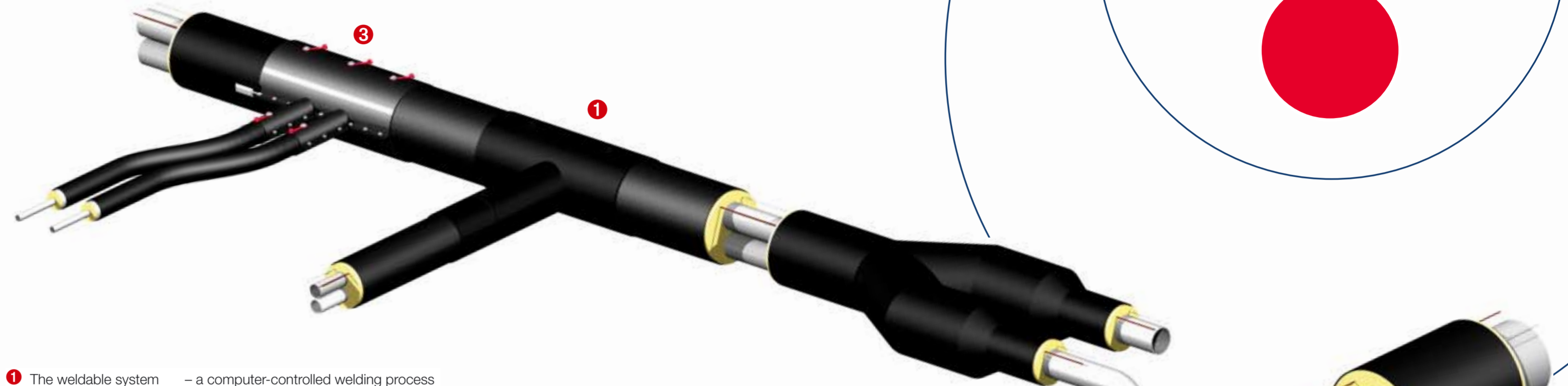

- 1 The weldable system – a computer-controlled welding process melts the joint and casing together into one unbreakable, sealed unit.
- 2 The shrinkable system – the joint (installed before the pipe is welded) is heat-shrunk onto the casing. This involves only one single joint and one foaming procedure for each joint, bend and branch.
- 3 The mechanical system – this is installed on site and involves only one single joint and one foaming procedure for each joint, bend and branch.



Monitoring systems

LOGSTOR pre-insulated pipes have copper wires running through the insulation. These sensors can be linked to electronic monitoring systems that identify the exact location if the service pipe, insulation or the casing suffers any form of damage.

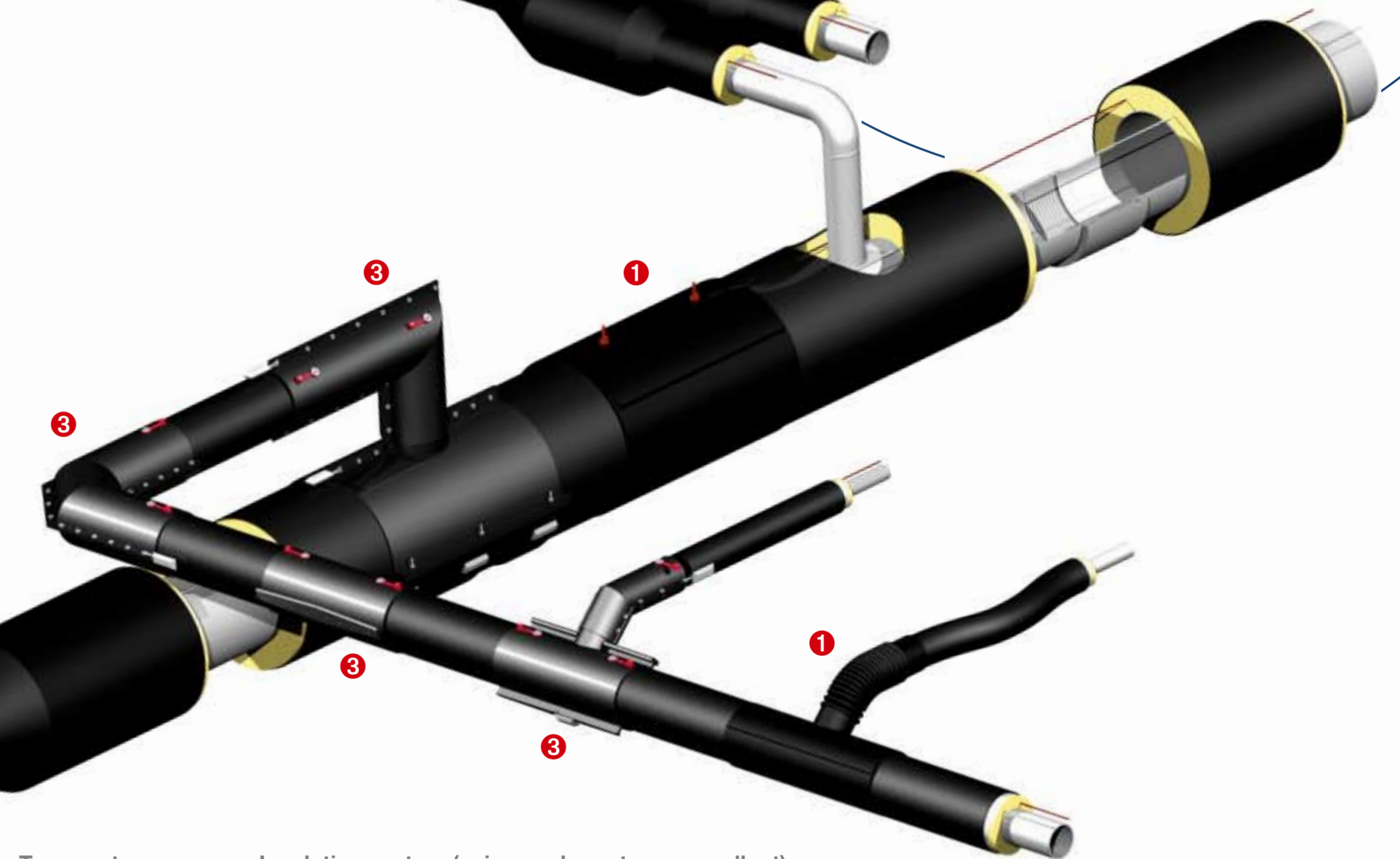

Temperature range

- From -200°C to 65°C
- From -60°C to 140°C
- From 5°C to 315°C

Insulation system (using cyclopentane propellant)

- Low-temperature, high-density polyurethane
- Standard high-density polyurethane
- HT2 – combination of mineral wool and high-density polyurethane

[We document the difference]